

T100 - Process volume capacity 100 L per cycle.



Our patented process is designed to **shred and sterilize** infectious waste by saturated steam. Shredding and sterilization are achieved in one fully enclosed and automated, stainless steel, system with no intermediate waste handling.

The contaminated waste is loaded into the upper chamber where a heavy-duty shredder reduces the waste into small pieces. Using gravity, the processed material drops into the lower treatment chamber.



After shredding, waste and all the inner parts of the machine are steam heated to 138°C (280 F) and pressurized to 3,5 bar (51 psi).



Sterilization is achieved by maintaining a temperature of 138°C (280 F) at the core of the waste for 10 minutes.



After the cooling process, the final product is safe to recycle or to dispose as ordinary waste. Waste are both sterilized (Microbial inactivation = 10⁸) and volume-reduced by up to 80 %.



The 30 minutes duration of an average cycle process is fully automated and totally monitored. A computerized control system scans the process and automatically prints and records on a memory card a batch report at the end of each cycle with the essential sterilizing parameters for accurate record keeping.

Approved by the Higher Council of Public Health of France under the direction of the Ministry of Health and the Ministry of the Environment.

ASME



T100

- Process volume capacity 100 L per cycle.



Technical specifications

General Characteristics

Dimensions (L x W x H)	200 x 120 x 212 cm 6,6 x 3,8 x 7 ft
Shipping Weight	635 kg
Max weight when filled with water For a special hydraulic test.	780 kg
Stress	0,1 kg/cm ²
Steam Pressure	8 bar
Max Steam Flow	35 kg/h
Compressed Air	6 bar
Electricity 380 V / 3-Phase	5 kW

Operating Characteristics

Average Cycle Time	30 minutes
Process Volume Capacity	100 liters
Average Waste Density	100 - 150 kg/m ³
Average Process Weight Capacity	10 - 15 kg/cycle 22 - 33 lb/cycle
Microbial Inactivation	10 ⁸
Waste Volume Reduction	80%

Consumption / cycle

Steam	6 kg
Electricity	0,55 kWh
Water	5 liters

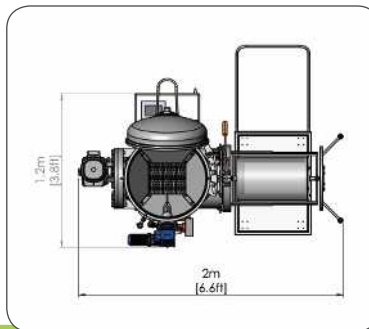
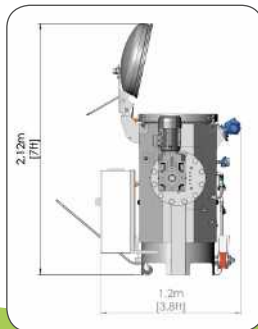
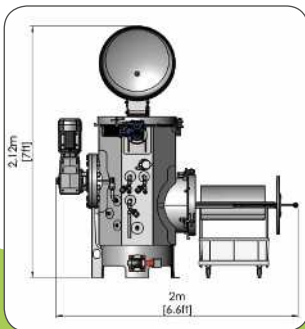
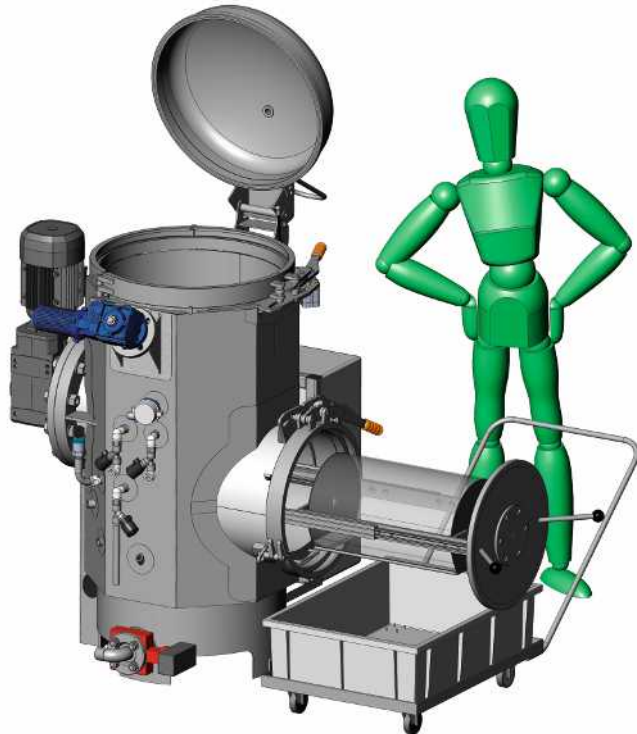

28 rue Sébastopol
59100 ROUBAIX - FRANCE

Tél. +333 20 70 98 65
Fax +333 20 36 28 05

contact@ecodas.com
www.ecodas.com

